

*Ernest George Chormann's*

2 Sheets.

117513

*Universal Slide Rest*

Sheet No. 1.

PATENTED AUG 1 1871

*Fig. 3.*

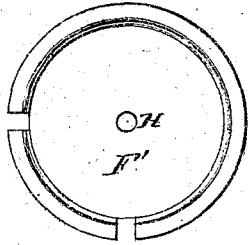

*Fig. 2.*

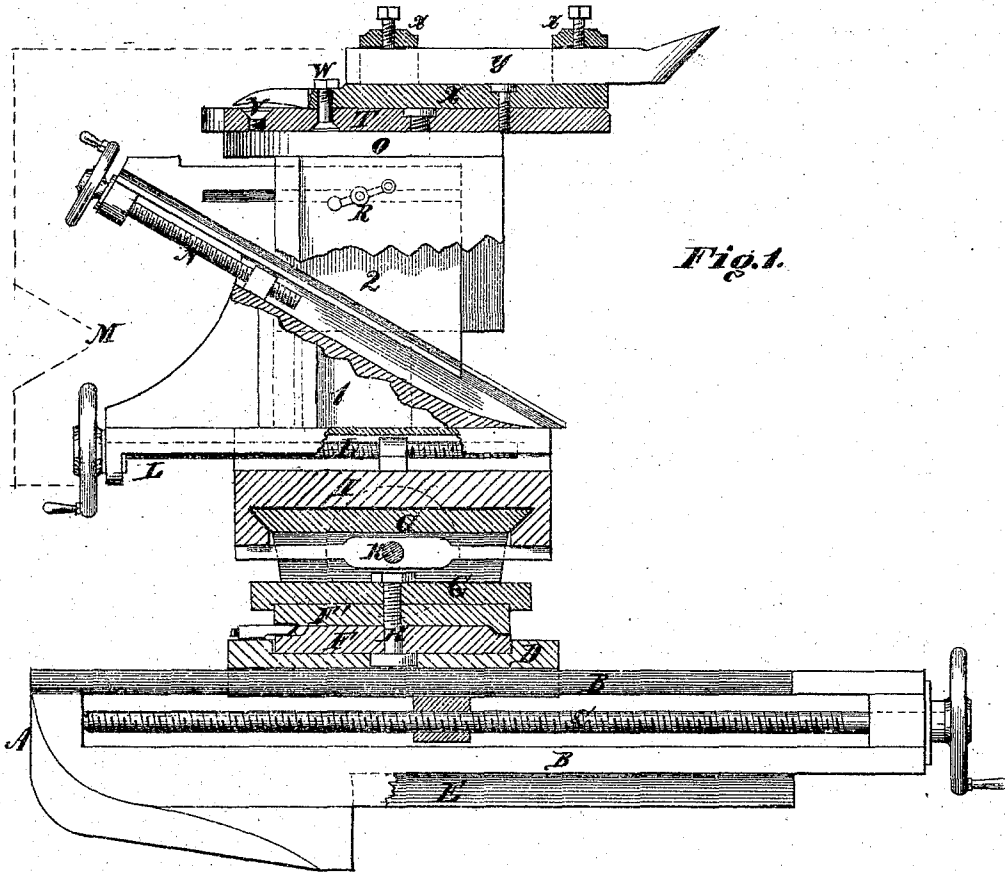
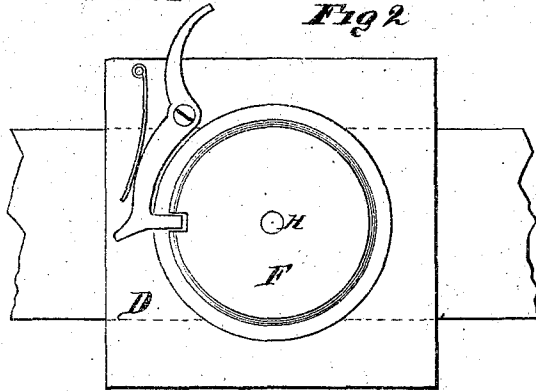

*Fig. 1.*

*Witnesses.*

*Edgar L. Thomson.*

*Albert S. L. Shields.*

*Inventor.*

*Ernest George Chormann.*  
*by his attorney.*

*Franklin C. Tilton.*

*Ernest George Chormann's  
Universal Slide Rest*

2 Sheets.

Sheet No. 2.

117513

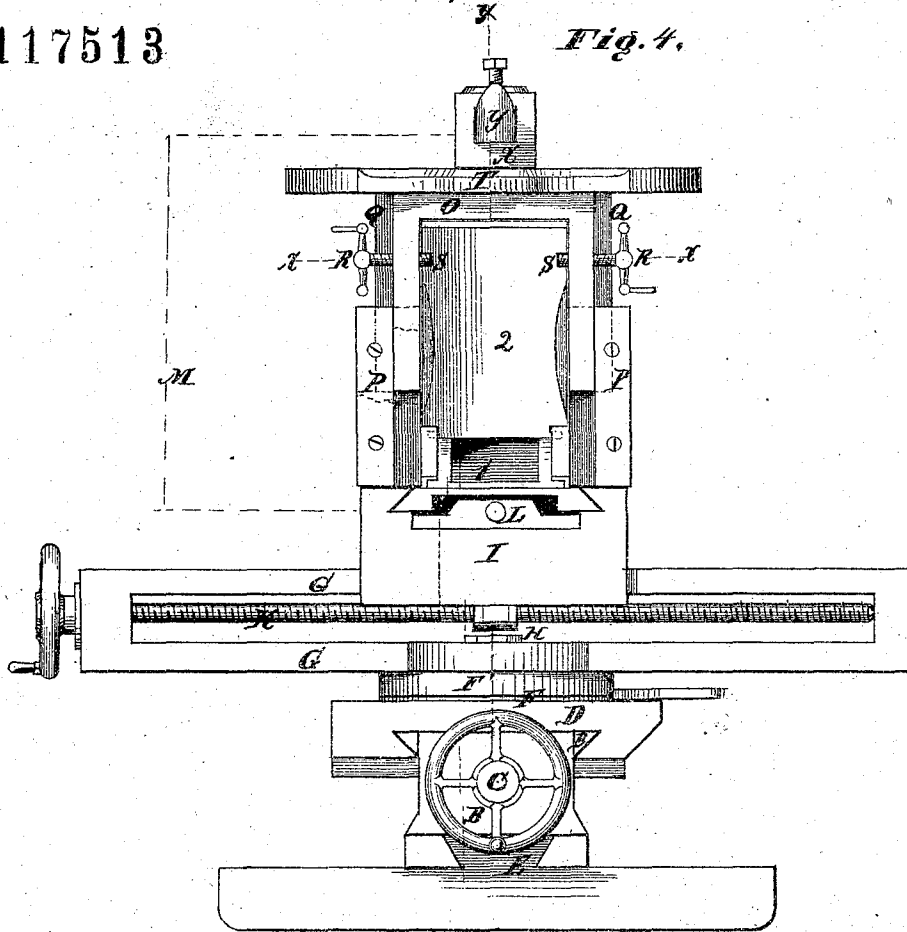

Fig. 4.

Fig. 5.

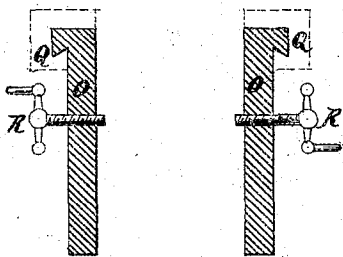
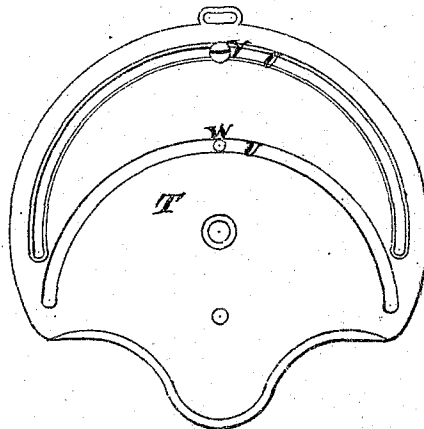

Fig. 6.



*Witnesses.*

*Edgar L. Thomson,  
Albert S. L. Shields*

*Inventor.*

*Ernest George Chormann  
by his Attorney  
Franklin E. Felton*

# UNITED STATES PATENT OFFICE.

ERNEST GEORGE CHORMANN, OF PHILADELPHIA, PENNSYLVANIA.

## IMPROVEMENT IN UNIVERSAL SLIDE-RESTS FOR LATHES.

Specification forming part of Letters Patent No. 117,513, dated August 1, 1871.

*To all whom it may concern:*

Be it known that I, ERNEST GEORGE CHORMANN, of the city of Philadelphia and State of Pennsylvania, have invented an Improved Rest for Lathes and similar mechanism, which I denominate the "Universal Slide-Rest."

The object of my invention is the creation of a rest for lathes and similar mechanism that will so operate as to present the cutting-tool at any desired angle, and to elevate and depress the same at the will of the operator. The use of my rest supersedes the customary method of "wedging up" the tool by collars, loose wedges, or analogous means. The wedging-up process wastes the time and distracts the attention of the operator when required to adjust the tool to any requisite position, and is unsatisfactory in its results in consequence of the tremulous movement of the tool, which is insecurely held in the tool-holder, and rests on collars or wedges that imperfectly support it. The "Universal slide-rest" can be instantaneously adjusted parallel with the lathe-bed and be readily changed parallel to the face-plate, thereby obviating the necessity of testing the work by a square to determine whether the rest is accurately adjusted, as is the usual practice, which causes loss of time and waste of material, and not infrequently spoils the work. In adjusting the ordinary compound slide-rests it is necessary to hammer them into position, and they are consequently battered by the blows and soon rendered unserviceable. The easy adjustment of my rest avoids this defect, and the consequent exemption from injury diminishes the cost of repairs and gives it increased durability. When my rest is properly adjusted it is unnecessary to shift it for turning different diameters, in which respect it has a material advantage over the ordinary compound or detached rests. My rest is compact in form, simple in construction, economical in cost, readily understood, and easily operated.

Figure 1 is a vertical central section of my apparatus. Figs. 2 and 3 represent the clutch movement. Fig. 4 is a transverse central section of my apparatus. Fig. 5 is a sectional view of the cap through the line *x x*. Fig. 6 is a face view of the tool-revolving plate.

A represents the base of the rest, and is composed of the two parallel plates, B B, placed at right angles to the lathe, one above the other.

Between these plates traverses the screw C. The upper plate serves as a slide, on which moves the bearing D, actuated by the screw C. A shoulder, E, cast on the lower plate and projecting below it, presses against the outside of the lathe, and, in conjunction with the usual fastening, serves to hold the base in position at right angles to, or parallel with, the lathe. F is a flanged, convex, stationary disk, cast on or affixed to the bearing, and notched in its periphery for the purpose of locking the shear G. F' is a concave, flanged, movable disk, resting on the stationary disk, on which it revolves. It is likewise notched on its periphery for the purpose of locking the shear G, of which it constitutes a part, by a clutch or other suitable device. From the center of the bearing D protrudes a vertical screw, H, through the center of the disks F F' into the shear G, which rotates thereon. The screw H is provided with a nut for clamping the shear G, on which the slide proper I traverses to and fro, actuated by the screw K that passes through the upper and lower plates which form the shear. L is a feed-screw that operates the slide M to feed the tool to the work, and which slide comprises the upper section of the rest. The slide proper I is composed of the angle-plates 1 2, placed one above the other. The top angle-plate is actuated by the screw N, that passes obliquely between the angle-plates and parallel with their planes. Over the angle-plates is a movable cap, O, to which a vertical movement is imparted by the combined action of the top angle-plate and the screw working in the planes of the angle-plates, which movement elevates or depresses the tool at the will of the operator. At each side of the cap O is a guide, P, that engages in the bearing Q on the lower angle-plate, and this arrangement gives a true and firm movement to the cap. On each side of the cap is a set-screw, R, that engages in the slot S on the top angle-plate, by which means the cap is depressed when the angle-plate retrogrades. A rotating temple-plate, T, rests on the cap O and is fastened at the center by a double cone-bearing or other suitable device. On the rear portion of the tool-revolving plate are two semicircular slots, U U. An adjusting-screw, V, set on the cap O and engaging in the outer slot, serves to clamp the temple-plate at any desired horizontal angle. In the inner slot traverses an adjustable screw, W, that is fast-

ened to the tool-holder X, which is secured at its inner extremity to the tool-revolving plate by a double cone-bearing or other suitable device. By this arrangement the tool-holder may be adjusted to any desired angle independently of the movement of the tool-revolving plate. By the combined action of the tool-holder and the tool-revolving plate the tool-holder can be made to traverse across the movable cap to any desired point. The exterior edge of the tool-revolving plate may be graduated, and the rear part of the tool-holder can be so fashioned as to serve as an index, and thus absolute precision can be attained in the adjustment of the tool Y, which is rigidly held in the tool-holder by set-screws, worked, preferably, by crank-handles or by other mechanical contrivances.

I claim as my invention—

A rest for lathes and similar machines, formed of the base A, composed of the parallel connected plates B B, the screw C, the bearing D, the shoulder E, the stationary disk F, the movable disk F', the shear G, the screw H, the slide proper I, the screw K, the feed-screw L, and the slide M, consisting of the angle-plates 1 2, the screw N, the movable cap O, the guide P, the bearing Q, the set-screw R, the slot S, the temple-plate T, the semicircular slots U U', the adjusting-screw V, the adjustable screw W, the temple or tool-holder X, and the tool Y, or their equivalents, arranged, constructed, and operating in the manner and for the purposes substantially as described.

Witnesses: E. G. CHORMANN.  
FRANKLIN E. FELTON,  
EDGAR L. THOMSON.